

## PHOTONIC ANALOG TO DIGITAL CONVERSION

Digitalization of data opens unprecedented opportunities in telecommunication, radar and signal processing. Almost all sensing systems in use today require analog signals to be converted to digital ones. Signal rates have grown at a rate that has outpaced electronic analog to digital conversion (ADC). This demand for higher bandwidth, speed or digitalization precision puts stringent requirements on the aperture jitter of ADC setups. One way to improve ADC is to use a lower timing-jitter clock source provided by photonic solutions. Photonic ADCs benefit from much more than only improved timing-jitter. Using mode-locked laser sources like the MENHIR-1550 laser enables a wide variety of new ultra-fast photonic digitization techniques.

We show here how the MENHIR-1550 can be used to clock an ADC at much higher bandwidths while at same time achieving timing-jitter below 1 fs.

### Menhir Photonics' product strengths

Lowest timing-jitter  
on the market

High-repetition rates  
up to 2.5 GHz

Ultra-high pulse amplitude  
reproducibility

### Application use case

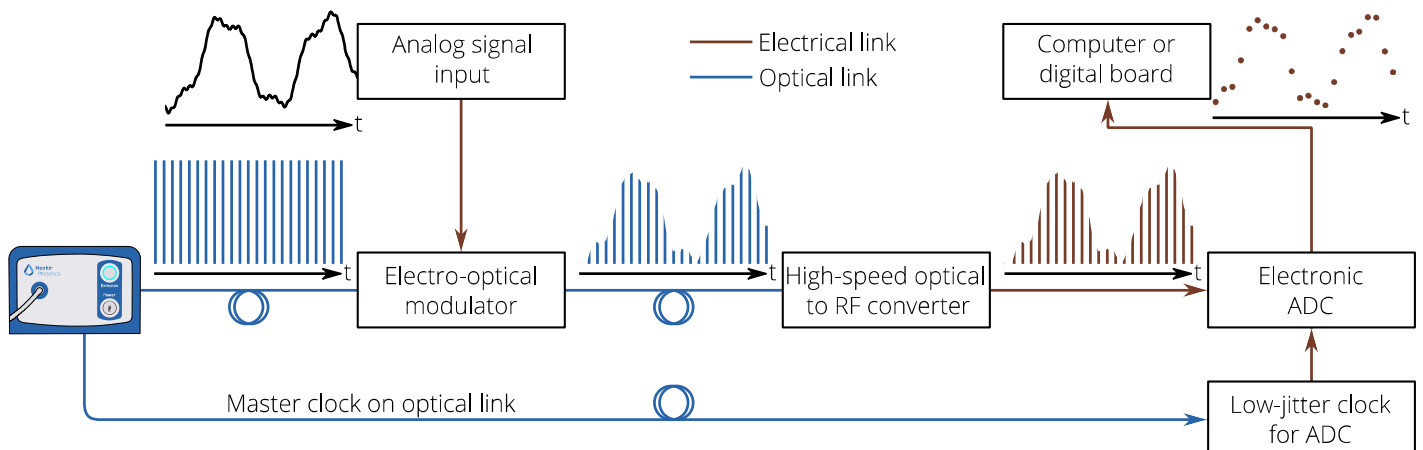

Figure 1 — Example of a photonic ADC where the passively mode-locked laser (MENHIR-1550) is used to sample optically the incoming signal and distribute ultra-low timing-jitter clock to the electronic ADC converter. The intensity of each laser pulse (in blue) is modulated by the signal to digitize and the opto-electronic converter produces voltage pulses, which are the sampled image of the input signal. An electronic ADC digitizes the incoming electrical pulses to a computer board.

### Sampling at exact defined times

The Figure 1 depicts a typical photonic ADC setup. The source signal to digitize is sampled in the optical domain. This is achieved by the electro-optical modulator, which tunes the intensity of the incoming pulses

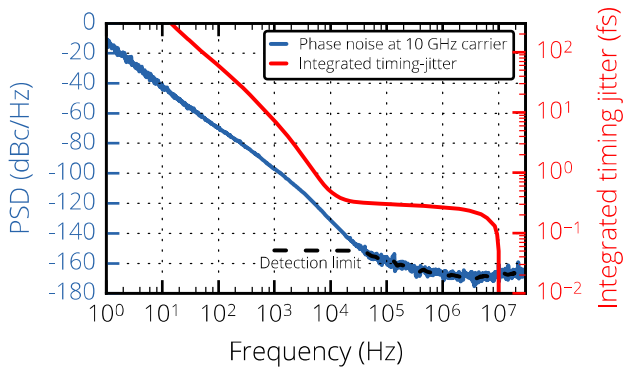

Figure 2 — Timing-jitter (left/blue) and integrated timing-jitter (right/red) of the MENHIR-1550 laser recorded on the 10<sup>th</sup> harmonic (10 GHz). The timing-jitter scales in the atto-second level, much lower than our setup detection limit, corresponding to the black dashed-line.

from the MENHIR-1550 laser accordingly to the input signal. The pulse train intensity perfectly reflects the input signal, which is sampled at exact and known times. The short pulse width from the laser (< 250 fs) ensures a good sampling even with fast-varying input signals.

To improve the performances of the ADC, the key aspect is to reduce the aperture jitter, i.e., to sample at the correct time. Figure 2 shows the timing-jitter performance (in red, right scale) of the MENHIR-1550 laser. Timing-jitter of less than 1 fs is achievable over the frequency range of 10 kHz – 1 MHz at a repetition frequency of 1 GHz (higher values are available).

## Amplitude stability for quantization

High effective number of bits (ENOB) requires low-noise signal at the input of the ADC. This condition is only met if the laser source demonstrates a low-level amplitude noise. Thanks to the extreme robustness of the MENHIR-1550 laser, the pulse amplitude variations are lower than 0.01% over 10<sup>9</sup> subsequent pulses, as reported in the Figure 3. This extreme stability ensures that the ADC quantizes the correct value of the signal, at the correct time.

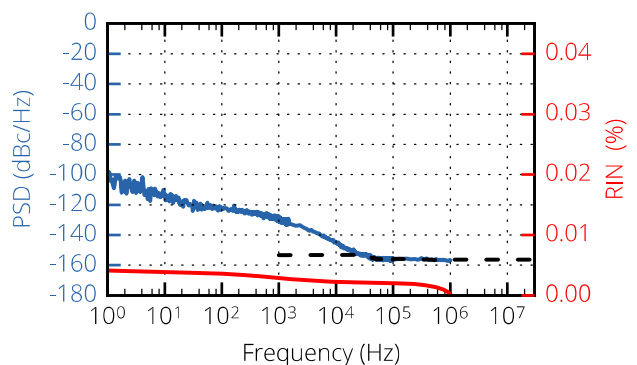

Figure 3 — Amplitude noise power spectral density (left/blue) and relative intensity noise (right/red) for the MENHIR-1550 laser.

## References

1. G. C. Valley, *Photonic analog-to-digital converter*, Optics Express **15**, 1955 (2007)
2. A. Khilo, S. J. Spector, M. E. Grein, A. H. Nejadmalayeri, C. W. Holzwarth, M. Y. Sander, M. S. Dahlem, M. Y. Peng, M. W. Geis, N. A. DiLello, J. U. Yoon, A. Motamedi, J. S. Orcutt, J. P. Wang, C. M. Sorace-Agaskar, M. A. Popović, J. Sun, G.-R. Zhou, H. B., J. Chen, J. L. Hoyt, H. I. Smith, R. J. Ram, M. Perrott, T. M. Lyszczarz, E. P. Ippen, F. X. Kärtner, *Photonic ADC: overcoming the bottleneck of electronic jitter*, Optics Express **20**, 4454 (2012)

## Related product: MENHIR-1550 at 1.0 GHz

Repetition rate	1.0 GHz (higher values available)
Average power	> 50 mW
Central wavelength	1555 +/- 10 nm
Spectral bandwidth at -3 dB	> 10 nm (i.e. sub-250 fs pulses, at -3 dB). Allows wavelength division multiplexing.

## Contact & Info

For further information, please contact [Menhir Photonics](https://www.menhir-photonics.com) at [contact@menhir-photonics.com](mailto:contact@menhir-photonics.com). Find more videos and tutorials on this topic in our [Youtube channel](#).